

AIR CONDITIONER Wall Mounted Type

INSTALLATION MANUAL

PART No. 9332622072-02

1. SAFETY PRECAUTIONS

- Be sure to read this manual thoroughly before installation.
- Warnings and precautions indicated in this manual contain important information pertaining to your safety. Be sure to observe them.
- Hand this manual, together with the operating manual, to the customer. Request the customer to keep them on hand for future use, such as for relocating or repairing the unit.

WARNING This mark indicates procedures which, if improperly performed, might lead to the death or serious injury of the user.

- Installation of this product must be done by experienced service technicians or professional installers only in accordance with this manual. Installation by non-professional or improper installation of the product might cause serious accidents such as injury, water leakage, electric shock, or fire. If the product is installed in disregard of the instructions in this manual, it will void the manufacturer's warranty.
- Do not turn on the power until all work has been completed. Turning on the power before the work is completed can cause serious accidents such as an electric shock or a fire.
- If refrigerant leaks when you are working, ventilate the area. If the leaking refrigerant is exposed to a direct flame, it may produce a toxic gas.
- Installation must be performed in accordance with regulations, codes, and standards for electrical wiring and equipment in each country, region, or the installing place.
- Do not use this equipment with air or any other unspecified refrigerant in the refrigerant lines. Excess pressure can cause a rupture.
- During installation, make sure that the refrigerant pipe is attached firmly before you run the compressor. Do not operate the compressor under the condition of refrigerant piping not attached properly with 2 way or 3 way valve open. This may cause abnormal pressure in the refrigeration cycle that leads to rupture and even injury.
- During the pump-down operation, make sure that the compressor is turned off before you remove the refrigerant piping. Do not remove the connection pipe while the compressor is in operation with 2-way or 3-way valve open. This may cause abnormal pressure in the refrigeration cycle that leads to breakage and even injury.
- This appliance is not intended for use by persons (including children) with reduced physical, sensory or mental capabilities, or lack of experience and knowledge, unless they have been given supervision or instruction concerning use of the appliance by a person responsible for their safety. Children should be supervised to ensure that they do not play with the appliance.

CAUTION This mark indicates a potentially hazardous situation that may result in minor or moderate injury or damage to property.

- Read carefully all of safety information written in this manual before you install or use the air conditioner.
- This unit must be installed by qualified personnel with a capacity certification of handling refrigerant fluids. Refer to regulation and laws in use on installation place.
- Install the unit by following local codes and regulations in force in the place of installation, and the instructions provided by manufacturer.
- This unit is part of a set constituting an air conditioner. The unit must not be installed alone or be installed with non-authorized device by the manufacturer.
- Always use a separate power supply line protected by a circuit breaker operating on all wires with a distance between contact of 3 mm for this unit.
- To protect the persons, ground the unit correctly, and use the power cable combined with an Earth Leakage Circuit Breaker (ELCB).
- The units are not explosion proof, and therefore should not be installed in explosive atmosphere.
- To avoid getting an electric shock, never touch the electrical components soon after the power supply has been turned off. After turning off the power, always wait 5 minutes or more before you touch the electrical components.
- This unit contains no user-serviceable part. Always consult experienced service technician for repairing.
- Do not touch the aluminum fins of heat exchanger built-in the indoor or outdoor unit to avoid personal injury when you install the unit.
- When moving or relocating the air conditioner, consult experienced service technicians for disconnection and reinstallation of the unit.
- Do not place any other electrical products or household belongings under indoor unit or outdoor unit. Dripping condensation from the unit might get them wet, and may cause damage or malfunction of your property.

2. ABOUT THE UNIT

Precautions for using R410A refrigerant

- The basic installation work procedures are the same as conventional refrigerant (R22) models. However, pay careful attention to the following points.
- Since the working pressure is 1.6 times higher than that of conventional refrigerant (R22) models, some of the piping and installation and service tools are special. (See the table below.) Especially, when replacing a conventional refrigerant (R22) model with a new refrigerant R410A model, always replace the conventional piping and flare nuts with the R410A piping and flare nuts.
- Models that use refrigerant R410A have a different charging port thread diameter to prevent erroneous charging with conventional refrigerant (R22) and for safety. Therefore, check beforehand. [The charging port thread diameter for R410A is 1/2 inch.]
- Be more careful that foreign matter (oil, water, etc.) does not enter the piping than with refrigerant (R22) models. Also, when storing the piping, securely seal the opening by pinching, taping, etc.
- When charging the refrigerant, take into account the slight change in the composition of the gas and liquid phases. And always charge from the liquid phase where refrigerant composition is stable.

Special tools for R410A

Gauge manifold Pressure is high and cannot be measured with a conventional (R22) gauge. To prevent erroneous mixing of other refrigerants, the diameter of each port has been changed. It is recommended the gauge with seals -0.1 to 5.3 MPa (-1 to 53 bar) for high pressure. -0.1 to 3.8 MPa (-1 to 38 bar) for low pressure.
Charge hose To increase pressure resistance, the hose material and base size were changed.
Vacuum pump A conventional vacuum pump can be used by installing a vacuum pump adapter.
Gas leakage detector Special gas leakage detector for HFC refrigerant R410A.

Copper pipes

It is necessary to use seamless copper pipes and it is desirable that the amount of residual oil is less than 40 mg/10 m. Do not use copper pipes having a collapsed, deformed or discolored portion (especially on the interior surface). Otherwise, the expansion valve or capillary tube may become blocked with contaminants. As an air conditioner using R410A incurs pressure higher than when using R22, it is necessary to choose adequate materials. Thicknesses of copper pipes used with R410A are as shown in chart below. Never use copper pipes thinner than 0.8mm even when it is available on the market.

Thicknesses of Annealed Copper Pipes

		Thickness (mm)	
Nominal diameter	Outer diameter (mm)	R410A	[ref.] R22
1/4 in.	6.35	0.80	0.80
3/8 in.	9.52	0.80	0.80

WARNING

Do not use the existing (for R22) piping and flare nuts.
If the existing materials are used, the pressure inside the refrigerant cycle will rise and cause failure, injury, etc. (Use the special R410A materials.)

When installing and relocating the air conditioner, do not mix gases other than the specified refrigerant (R410A) to enter the refrigerant cycle.
If air or other gas enters the refrigerant cycle, the pressure inside the cycle will rise to an abnormally high value and cause failure, injury, etc.

For authorized service personnel only

WARNING

- For appropriate working of the air conditioner, install it as written in this manual.
- To connect indoor unit and outdoor unit, use air conditioner piping and cables available through your local distributor. This manual describes proper connections using such installation set.
- Installation work must be performed in accordance with national wiring standards by authorized personnel only.
- Do not turn on the power until all work has been completed.

- Be careful not to scratch the air conditioner when handling it.
- After installation, explain correct operation to the customer, using the operating manual.

Accessories

The following installation accessories are supplied. Use them as required.

Name and Shape	Q'ty	Name and Shape	Q'ty	Name and Shape	Q'ty
Operating manual	1	Installation manual (This manual)	1	Wall hook bracket	1
Remote controller	1	Battery	2	Cloth tape	1
		Tapping screw (M4 × 25 mm)	5	Drain pipe	1

The following items are necessary to install this air conditioner. (The items are not included with the air conditioner and must be purchased separately.)

Name	Q'ty	Name	Q'ty
Connection pipe assembly	1	Wall cap	1
Connection cable	1	Saddle	1 set
Wall pipe	1	Drain hose	1
Decorative tape	1	Tapping screws	1 set
Vinyl tape	1	Sealant	1

3. ELECTRICAL REQUIREMENT

- Always make the air conditioner power supply a special branch circuit and provide a special switch and receptacle. Do not extend the power cable.
- Install the disconnect device with a contact gap of at least 3 mm nearby the units.

Cable	Size (mm2)*1	Type	Remarks
Connection cable	1.5	Type 60245 IEC 57	3 cable + Earth (Ground), 1 Ø 230V

*1 Selected sample: Select the correct cable type and size according to the country or region's regulations.
Max. wire length: Set a length so that the voltage drop is less than 2%. Increase the wire diameter when the wire length is long.

WARNING

- The rated voltage of this product is 230 V AC 50 Hz.
- Before turning on the power, check if the voltage is within the 220 V -10 % to 240 V +10 % range.
- Always use a special branch circuit and install a special receptacle to supply power to the room air conditioner.
- Use a circuit breaker and receptacle matched to the capacity of the air conditioner.
- Do not extend the power cable.
- Perform wiring work in accordance with standards so that the air conditioner can be operated safely and correctly.
- Install a leakage circuit breaker in accordance with the related laws and regulations and electric company standards.

CAUTION

- The power source capacity must be the sum of the air conditioner current and the current of other electrical appliances. When the current contracted capacity is insufficient, change the contracted capacity.
- When the voltage is low and the air conditioner is difficult to start, contact the power company for increasing the voltage.

4. INSTALLATION DIAGRAM

Installation dimensions

[INDOOR UNIT]

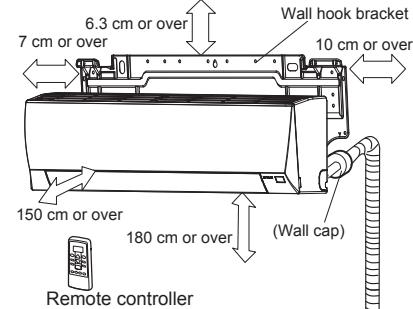

[OUTDOOR UNIT]

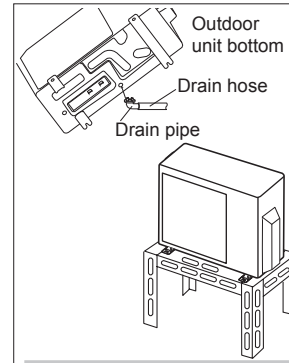
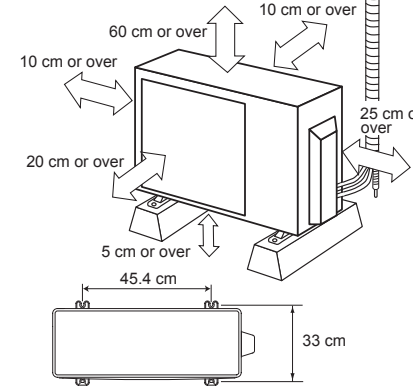

CAUTION

- When the outdoor temperature is 0 °C or less, do not use the accessory drain pipe and drain cap. If the drain pipe and drain cap are used, the drain water in the pipe may freeze in extremely cold weather. (Reverse cycle model only)
- In the area with heavy snowfall, if the intake and outlet of outdoor unit is blocked with snow, it might become difficult to get warm and it is likely to cause of the breakdown. Construct a canopy and a pedestal or place the unit on a high stand (local configured).

5. SELECTING THE MOUNTING POSITION

Decide the mounting position with the customer as follows:

- Do not set to a place where there is oily smoke, oil is used in the factory, the unit can contact sea breeze, sulfide gases will be generated in the hot spring area, corrosive gases will be generated, animal may urine on the unit and ammonia will be generated and a dusty place.

Indoor unit

- (1) Install the indoor unit level on a strong wall which is not subject to vibration.
- (2) The inlet and outlet ports should not be obstructed : the air should be able to blow all over the room.
- (3) Install the unit a dedicated electrical branch circuit.
- (4) Do not install the unit where it will be exposed to direct sunlight.
- (5) Install the unit where connection to the outdoor unit is easy.
- (6) Install the unit where the drain pipe can be easily installed.
- (7) Take servicing, etc. into consideration and leave the spaces shown in " 4. INSTALLATION DIAGRAM ". Also install the unit where the filter can be removed.
- (8) Indoor unit should be set to a place where it is free from the influence of the electronic instant on/off type fluorescent lamp and the thin TV screen.

Correct initial installation location is important because it is difficult to move unit after it is installed.

Outdoor unit

- (1) If possible, do not install the unit where it will be exposed to direct sunlight. (If necessary, install a blind that does not interfere with the air flow.)
- (2) Do not install the unit where a strong wind blows or where it is very dusty.
- (3) Do not install the unit where people pass.
- (4) Take you neighbors into consideration so that they are not disturbed by air blowing into their windows or by noise.
- (5) Provide the space shown in " 4. INSTALLATION DIAGRAM " so that the air flow is not blocked. Also for efficient operation, leave open three of the four directions front, rear, and both sides.
- (6) Install the unit where keep away more than 3m from the antenna of TV set and Radio.
- (7) Outdoor unit should be set to a place where both drainage and itself will not be affected when heating.

WARNING

Install the unit where is capable to support the weight of the unit. Secure the unit firmly so that the unit does not topple or fall.

CAUTION

- Do not install the unit in the following areas:
- Area with high salt content, such as at the seaside. It will deteriorate metal parts, causing the parts to fail or the unit to leak water.
 - Area filled with mineral oil or containing a large amount of splashed oil or steam, such as a kitchen. It will deteriorate plastic parts, causing the parts to fail or the unit to leak water.
 - Area where is close to heat sources.
 - Area that generates substances that adversely affect the equipment, such as sulfuric gas, chlorine gas, acid, or alkali.
- It will cause the copper pipes and brazed joints to corrode, which can cause refrigerant leakage.
- Area that can cause combustible gas to leak, contains suspended carbon fibers or flammable dust, or volatile inflammables such as paint thinner or gasoline.
 - If gas leaks and settles around the unit, it can cause a fire.
 - Area where animals may urinate on the unit or ammonia may be generated.

- Do not use the unit for special purposes, such as storing food, raising animals, growing plants, or preserving precision devices or art objects. It can degrade the quality of the preserved or stored objects.
- Install the unit where drainage does not cause any trouble.
- Install the indoor unit, outdoor unit, and power supply cable at least 1 m away from a television or radio receivers. The purpose of this is to prevent TV reception interference or radio noise. (Even if they are installed more than 1 m apart, you could still receive noise under some signal conditions.)
- If children may approach the unit, take preventive measures so that they cannot reach the unit.
- Install the indoor unit on the wall where the height from the floor is more than 1.8 m.

6. INDOOR UNIT INSTALLATION

Indoor unit piping direction

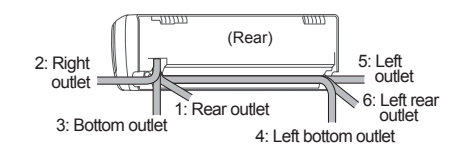

The piping can be connected in the 6 directions indicated in the following.
When the piping is connected in direction 2, 3, 4 or 5, cut along the piping groove in the side of the front cover with a hacksaw.

Cutting the hole in the wall for the connecting piping

- (1) Cut a 65 mm diameter hole in the wall at the position shown in the following.
- (2) Cut the hole so that the outside end is lower (5 to 10 mm) than the inside end.
- (3) Always align the center of the wall hole. If misaligned, water leakage will occur.
- (4) Cut the wall pipe to match the wall thickness, stick it into the wall cap, fasten the cap with vinyl tape, and stick the pipe through the hole.
- (5) For left piping and right piping, cut the hole a little lower so that drain water will flow freely.

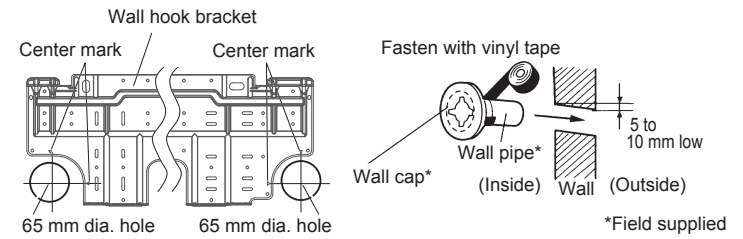

WARNING

Always use the wall pipe. If the wall pipe is not used, the cable that is connected between the indoor unit and the outdoor unit may touch metal, and cause an electric discharge.

Installing the wall hook bracket

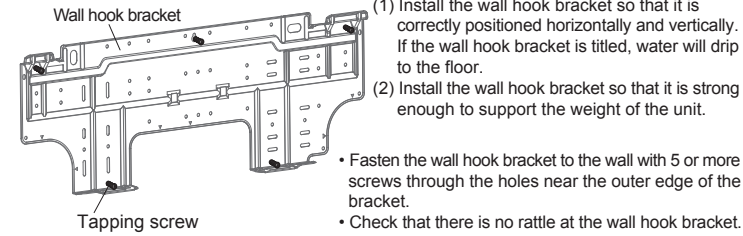

- (1) Install the wall hook bracket so that it is correctly positioned horizontally and vertically. If the wall hook bracket is tilted, water will drip to the floor.
- (2) Install the wall hook bracket so that it is strong enough to support the weight of the unit.

- Fasten the wall hook bracket to the wall with 5 or more screws through the holes near the outer edge of the bracket.
- Check that there is no rattle at the wall hook bracket.

CAUTION

Install the wall hook bracket both horizontally and vertically aligned. Misaligned installation may cause water leakage.

Forming the drain hose and pipe

[Rear piping, Right piping, Bottom piping]

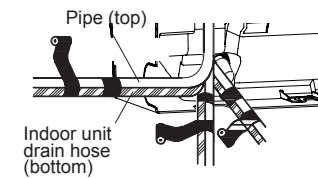

- Install the indoor unit piping in the direction of the wall hole and bind the drain hose and pipe together with vinyl tape.
- Install the piping so that the drain hose is at the bottom.
- Wrap the pipe of the indoor unit that visible from the outside with decorative tape.
- For right or bottom outlet piping, cut off the piping outlet cutting groove with a hacksaw.

[For Left rear piping, Left piping]

Interchange the drain cap and the drain hose.

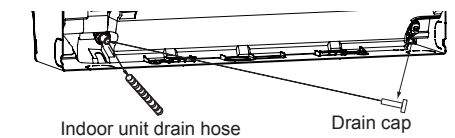

- For left or left bottom outlet piping, cut off the piping outlet cutting groove with a hacksaw.
- Remove the drain cap by pulling at the projection at the end of the cap with pliers, etc.

Installation method of Drain cap

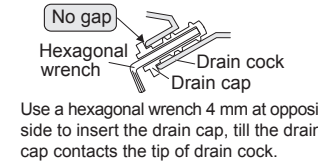

Use a hexagonal wrench 4 mm at opposite side to insert the drain cap, till the drain cap contacts the tip of drain cock.

Removal method of drain hose

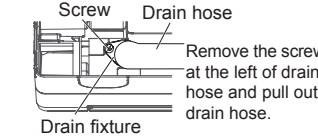

Hold around the joint of the drain hose during working. As the screw is inside, be sure to use screwdriver treated with magnet.

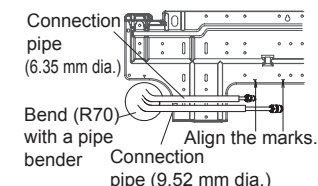

- For left piping and left rear piping, align the marks on the wall hook bracket and shape the connection pipe.
- Bend the connection piping at a bend radius of 70 mm or more and install no more than 35 mm from the wall.
- After passing the indoor piping and drain hose through the wall hole, hang the indoor unit on the hooks at the top and bottom of the wall hook bracket.

[Installing the indoor unit]

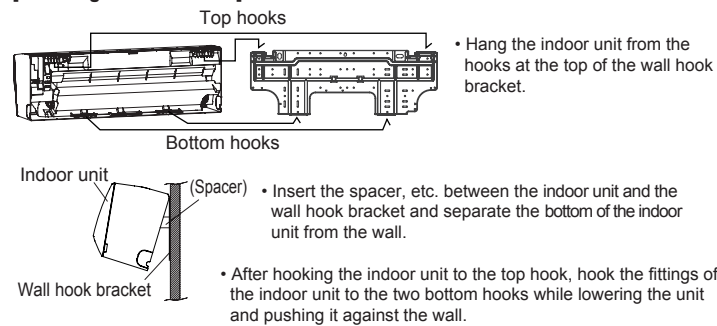

CAUTION

- Insert drain hose and drain cap securely. Drain should slope down to avoid water leakage.
- When inserting the drain hose, no other material than water should be applied. Application of other material than water will cause deterioration of the hose, and may cause water leakage.
- After you remove a drain hose, be sure to attach the drain cap.
- When you secure the piping and drain hose with tape, arrange the drain hose so that it comes under bottom of piping.
- For drain hose piping in low temperature environment, you need to apply frozen protection to prevent a frozen drain hose. After cooling operation is performed in low temperature environment, (when outdoor temperature under 0 °C.) water in the drain hose could be frozen. Frozen drain water will block the water flow in the hose, and may cause water leakage at the indoor unit.

Flare connection (Pipe connection)

Flaring

- (1) Cut the connection pipe to the necessary length with a pipe cutter.
- (2) Hold the pipe downward so that cuttings will not enter the pipe and remove the burrs.
- (3) Insert the flare nut onto the pipe and flare the pipe with a flaring tool.

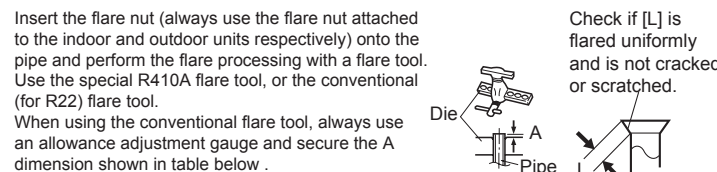

Pipe outside diameter

Pipe outside diameter	A (mm)		
	Flare tool for R410A Clutch type	Conventional (R22) flare tool Clutch type Wing nut type	
ø 6.35 mm (1/4")	0 to 0.5	1.0 to 1.5	1.5 to 2.0
ø 9.52 mm (3/8")	0 to 0.5	1.0 to 1.5	1.5 to 2.0

Connection

- (1) Install the outdoor unit wall cap (supplied with the optional installation set or procured at the site) to the wall pipe.
- (2) Connect the outdoor unit and indoor unit piping.
- (3) After matching the center of the flare surface and tightening the nut hand tight, tighten the nut to the specified tightening torque below with a torque wrench.

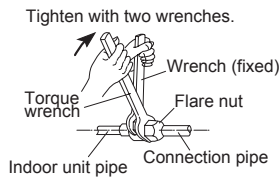

Flare nut size and tightening torque

Flare nut [mm (in.)]	Tightening torque [N·m (kgf·cm)]
6.35 (1/4) dia.	16 to 18 (160 to 180)
9.52 (3/8) dia.	32 to 42 (320 to 420)

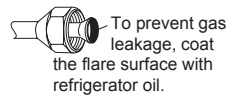

CAUTION

- Fasten a flare nut with a torque wrench as instructed in this manual. If fastened too tight, the flare nut may be broken after a long period of time and cause a leakage of refrigerant.

HOW TO CONNECT THE WIRE TO THE TERMINALS

- (1) Use ring terminals with insulating sleeves as shown in the figure below to connect to the terminal block.
- (2) Securely crimp the ring terminals to the wires using an appropriate tool so that the wires do not come loose.
- (3) Use the specified wires, connect them securely, and fasten them so that there is no stress placed on the terminals.
- (4) Use an appropriate screwdriver to tighten the terminal screws. Do not use a screwdriver that is too small, otherwise, the screw heads may be damaged and prevent the screws from being properly tightened.
- (5) Do not tighten the terminal screws too much, otherwise, the screws may break.
- (6) See the table below for the terminal screw tightening torques.

Tightening torque	
M3.5 screw	0.8 to 1.0 N·m (8 to 10 kgf·cm)
M4 screw	1.2 to 1.8 N·m (12 to 18 kgf·cm)
M5 screw	2.0 to 3.0 N·m (20 to 30 kgf·cm)

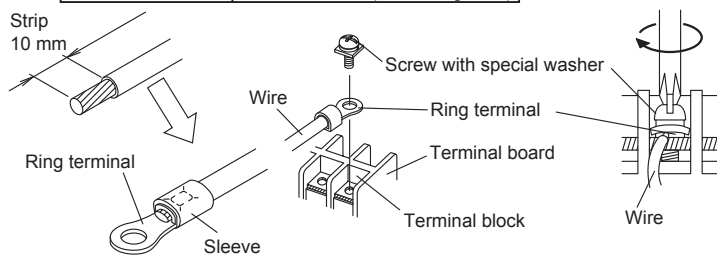

Indoor unit wiring

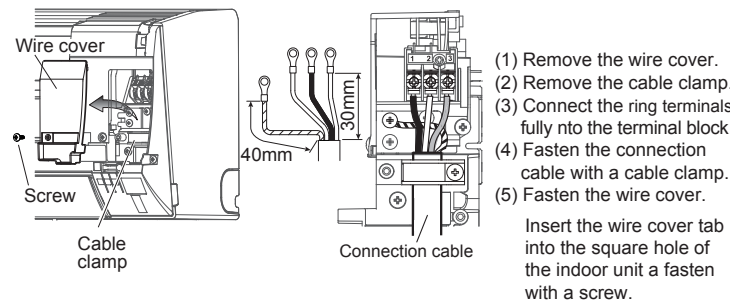

- (1) Remove the wire cover.
- (2) Remove the cable clamp.
- (3) Connect the ring terminals fully into the terminal block.
- (4) Fasten the connection cable with a cable clamp.
- (5) Fasten the wire cover.

Insert the wire cover tab into the square hole of the indoor unit a fasten with a screw.

CAUTION

- Match the terminal block numbers and connection cable colors with those of the outdoor unit. Incorrect wiring may cause a fire.
- When fixing the connection cable with the cable clamp, always fasten the cable at the plastic jacket portion, but not at the insulator portion. If the insulator is chafed, electric leakage may occur.
- Always connect the earth (ground) wire. Improper earthing (grounding) work can cause electric shocks.
- Connect the connection cables firmly to the terminal block. Imperfect installation may cause a fire.
- Do not use the ground screw for the indoor unit to the outdoor unit unless it is specified.

7. OUTDOOR UNIT INSTALLATION

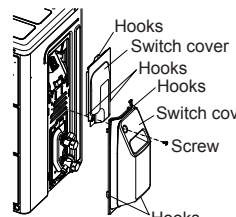

Switch cover A, B removal

- (1) Remove the tapping screws.
- (2) Push downward the Switch cover B.
- (3) Push upward the Switch cover A.

Installing the switch cover A, B

- (1) After inserting the three hooks of Switch cover A, then push upward.
- (2) After inserting the three hooks of Switch cover B, then push upward, and then tighten the tap ping screw.

WARNING

- Install the unit where it will not be tilted by more than 5°.
- When installing the outdoor unit where it may be exposed to strong wind, fasten it securely.

Air purge

Always use a vacuum pump to purge the air.
Refrigerant for purging the air is not charged in the outdoor unit at the factory.
 Close the high pressure side valve of the gauge manifold fully and do not operate it during the following work.

CAUTION

- Refrigerant must not be discharged into atmosphere.
- After connecting the piping, check the joints for gas leakage with gas leak detector.

- (1) Check if the piping connections are secure.
- (2) Check that the stems of 2-way valve and 3-way valve are closed fully.
- (3) Connect the gauge manifold charge hose to the charging port of the 3-way valve (side with the projection for pushing in the valve core).
- (4) Open the low pressure side valve of the gauge manifold fully.
- (5) Operate the vacuum pump and start pump down.
- (6) Slowly loosen the flare nut of the 3-way valve and check if air enters, then retighten the flare nut. (When the flare nut is loosened the operating sound of the vacuum pump changes and the reading of the compound pressure gauge goes from minus to zero.)
- (7) Pump down the system for at least 15 minutes, then check if the compound pressure gauge reads -0.1 MPa (-76 cmHg, -1 bar).
- (8) At the end of pump down, close the low pressure side gauge of the gauge manifold fully and stop the vacuum pump.
- (9) Slowly loosen the valve stem of the 3-way valve. When the compound pressure gauge reading reaches 0.1-0.2 MPa, retighten the valve stem and disconnect the charge hose from the 3-way valve charging port. (If the stem of the 3-way valve is opened fully before the charge hose is disconnected, it may be difficult to disconnect the charge hose.)
- (10) Fully open the valve stems of the 2-way valve and 3-way valve using a hexagon wrench. (After the valve stem begins to turn, turn it with a torque of less than 2.9 N·m until it stops turning.)
- (11) Firmly tighten the 2-way valve and 3-way valve blank cap and the charging port cap.

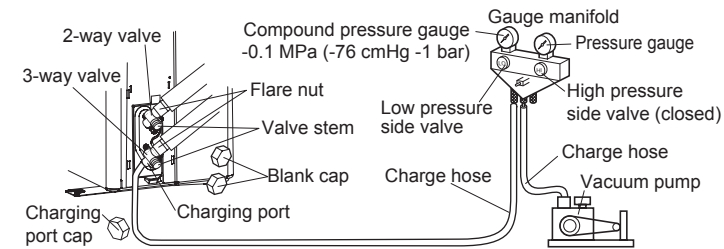

	Tightening torque [N·m(kgf·cm)]
Blank cap	20.0 to 25.0 (200 to 250)
Charging port cap	12.5 to 16.0 (125 to 160)

Additional charge

Refrigerant suitable for a piping length of 15 m is charged in the outdoor unit at the factory. When the piping is longer than 15 m, additional charging is necessary. For the additional amount, see the table below.

Pipe length	15 m	20 m	Rate
Additional refrigerant	None	+100 g	20 g/m

CAUTION

- When adding refrigerant, add the refrigerant from the charging port at the completion of work.
- The maximum length of the piping is 20 m. If the units are further apart than this, correct operation can not be guaranteed.

Between 15 m and 20m, when using a connection pipe other than that in the table, charge additional refrigerant with 20g/1 m as the criteria.

Outdoor unit wiring

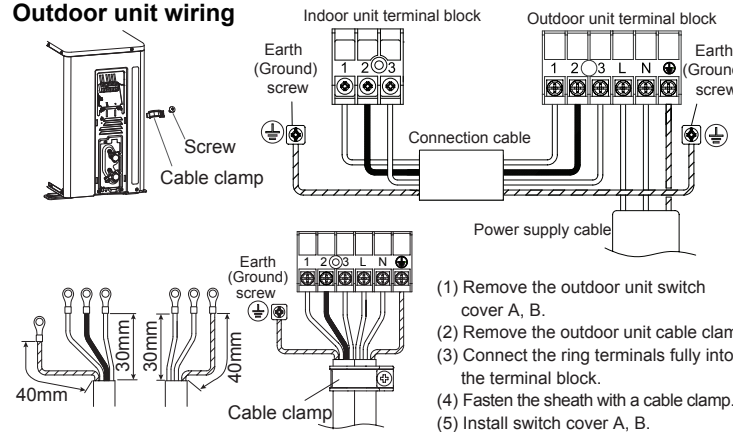

Connection cable wiring

- (1) Remove the outdoor unit switch cover A, B.
- (2) Remove the outdoor unit cable clamp.
- (3) Connect the ring terminals fully into the terminal block.
- (4) Fasten the sheath with a cable clamp.
- (5) Install switch cover A, B.

CAUTION

- Match the terminal block numbers and connection cable colors with those of the outdoor unit. Incorrect wiring may cause a fire.
- When fixing the connection cable with the cable clamp, always fasten the cable at the plastic jacket portion, but not at the insulator portion. If the insulator is chafed, electric leakage may occur.
- Always connect the earth(ground) wire. Improper earthing (grounding) work can cause electric shocks.
- Connect the connection cables firmly to the terminal block. Imperfect installation may cause a fire.
- Do not use the ground screw for the indoor unit to the outdoor unit unless it is specified.

8. FINISHING

- (1) Insulate between pipes.
 - For rear, right, and bottom piping, overlap the connection pipe insulation and indoor unit pipe insulation and bind them with vinyl tape so that there is no gap.
 - For left and left rear piping, butt the connection pipe insulation and indoor unit pipe insulation together and bind them with and vinyl tape so that there is no gap.
 - For left and left rear piping, wrap the area which accommodates the rear piping storage section with cloth tape.
 - For left and left rear piping, bind the connection cord to the top of the pipe with vinyl tape.
 - For left and left rear piping, bundle the piping and drain hose together by wrapping them with cloth tape over within the range of which they fit into the rear piping storage section.
- (2) Temporarily fasten the connection cord along the connection pipe with vinyl tape. (Wrap to about 1/3 the width of the tape from the bottom of the pipe with tape so that water does not enter.)
- (3) Fasten the connection pipe to the outside wall with saddles, etc.
- (4) Fill the gap between the outside wall pipe hole and the pipe with sealant so that rain water and wind cannot blow in.
- (5) Fasten the drain hose to the outside wall, etc.

For connection from the left rear

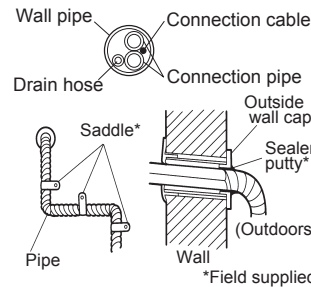

Check the following:

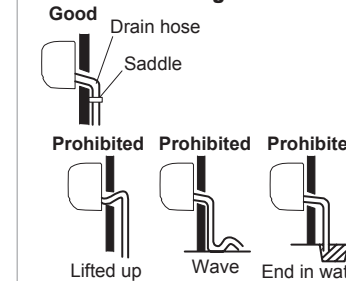

9. TEST RUN

- Perform test operation and check items 1 and 2 below.
- For the test operation method, refer to the operating manual.
- The outdoor unit, may not operate, depending on the room temperature. In this case, press the TEST RUN button on the remote controller while the air conditioner is running. (Point the transmitter section of the remote controller toward the air conditioner and press the test run button with the tip of a ball-point pen, etc.)
- To end test operation, press the remote controller START/STOP button. (When the air conditioner is run by pressing the test run button, the OPERATION indicator lamp and TIMER indicator lamp will simultaneously flash slowly.)

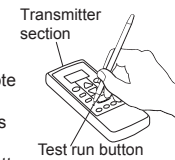

- 1. Indoor unit**
 - (1) Is operation of each button on the remote control unit normal?
 - (2) Does each lamp light normally?
 - (3) Do the airflow direction louver operate normally?
 - (4) Is the drain normal?
- 2. Outdoor unit**
 - (1) Is there any abnormal noise and vibration during operation?
 - (2) Will noise, wind, or drain water from the unit disturb the neighbors?
 - (3) Is there any gas leakage?

10. CUSTOMER GUIDANCE

Explain the following to the customer in accordance with the operating manual.

- (1) Starting and stopping method, operation switching, temperature adjustment, timer, airflow switching, and other remote controller operations.
- (2) Air filter removal and cleaning, and how to use the air louvers.
- (3) Give the operating and installation manuals to the customer.

11. FRONT PANEL REMOVAL AND INSTALLATION

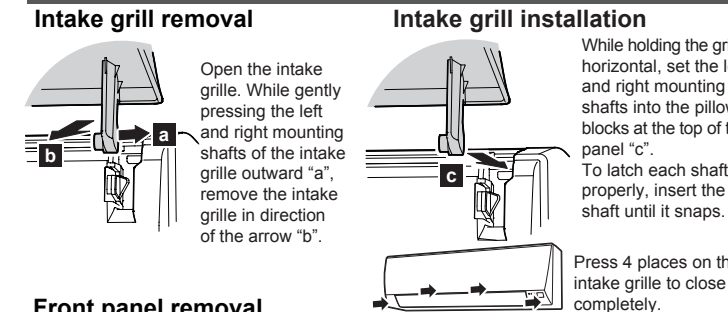

Front panel removal

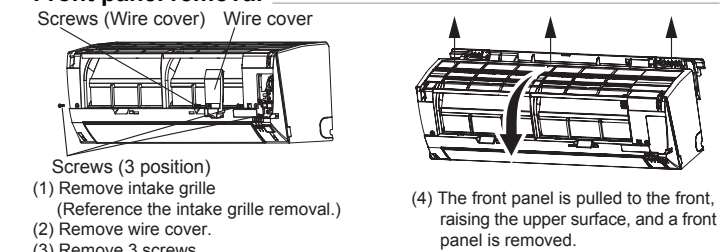

Front panel installation

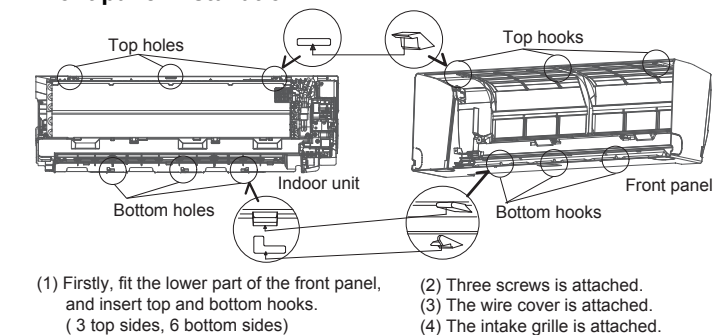

12. PUMP DOWN OPERATION (FORCED COOLING OPERATION)

To avoid discharging refrigerant into the atmosphere at the time of relocation or disposal, recover refrigerant by doing the cooling operation or forced cooling operation according to the following procedure. (When the cooling operation cannot start in winter, and so on, start the forced cooling operation.)

- (1) Do the air purging of the charge hose by connecting the charging hose of gauge manifold to the charging port of 3-way valve and opening the low-pressure valve slightly.
- (2) Close the valve stem of 2-way valve completely.
- (3) Start the cooling operation or following forced cooling operation.
 - Keep on pressing the MANUAL AUTO button of the indoor unit for more than 10 seconds. The operation indicator lamp and timer indicator lamp will begin to flash simultaneously during test run. (The forced cooling operation cannot start if the MANUAL AUTO button is not kept on pressing for more than 10 seconds.)
- (4) Close the valve stem of 3-way valve when the reading on the compound pressure gage becomes 0.05~0 Mpa (0.5~0 kg/cm2).
- (5) Stop the operation.
 - Press the START/STOP button of the remote controller to stop the operation.
 - Press the MANUAL AUTO button when stopping the operation from indoor unit side. (It is not necessary to press on keeping for more than 10 seconds.)

WARNING

During the pump-down operation, make sure that the compressor is turned off before you remove the refrigerant piping. Do not remove the connection pipe while the compressor is in operation with 2-way or 3-way valve open. This may cause abnormal pressure in the refrigeration cycle that leads to breakage and even injury.